

LOADER SPECIFICATIONS

L-1350

84,000 lbs (38,102 kgs) 28 yd³ (21.41 m³)
Standard Operating Capacity



LeTourneau, Inc.

Note: Optional equipment shown in photo.



POWER MODULE

DIESEL POWER OPTIONS

DETROIT DIESEL ENGINE

Model	Series 4000
Type	4-Cycle Turbocharged/Aftercooled
Rated Power	1600 HP (1193 kW @ 1900 RPM)
Cylinders	Twelve (12)
Bore and Stroke	6.5 in. X 7.5 in. (165 mm X 190 mm)
Displacement	2975 cu. in. (48.75 liters)

CUMMINS DIESEL ENGINE

Model	QSK 45
Type	4-Cycle Turbocharged/Aftercooled
Rated Power	1600 HP (1193 kW @ 1900 RPM)
Cylinders	Twelve (12)
Bore and Stroke	6.26 in. X 7.48 in. (159 mm X 190 mm)
Displacement	2746 cu. in. (44.99 liters)

RADIATOR/OIL COOLER

Model	Replaceable Tube Type, Split Flow Side By Side
Type	Thermostatically Controlled, Independent Hydraulic Motor-Driven Radiator Fan
Fan Speeds	Variable
Capacity	101 gals (382 l)

AIR FILTRATION

LeTourneau Self Cleaning KLENZ™ System
99.9% Efficiency Filtered Down to 0.3 Microns
Supply Filtered Air For:

Engine Air
Drive System Cooling
Pressurized Cab

EXHAUST SYSTEM

Low Restriction Mufflers With Top, Rear Hood Discharge



CONTROL SYSTEM-LINCSTM

LeTourneau Integrated Network Control System - LINCSTM

Microprocessor Based Full Digital Control and Monitoring

- Hydraulics • Electrics • Engine • Traction Drive

Modular Design

Built-in Diagnostics • Screen Display and Keypad

IGBT Switched Reluctance Controlled Traction Drive

No Contactors or Power Switch Gear

Infinitely Variable Speed Control

Built-in Standby Power Control



PROPULSION SYSTEM

Batteries	Four (4) 12-Volt
Model	8D
Starter(s)	Two (2) Delco-Remy 50 MT Type 400
Alternator	250 Amp With Integral Voltage Regulator

A.C. GENERATOR

Model	LeTourneau 9B Generator
Type	Alternating-Current, 3-Phase, 4-Pole
Excitation	Solid State
Feature	Standby Power Capability

TRACTION MOTORS

Model	LeTourneau B40 Traction Motor
Type	Switched Reluctance
Number	Four (4)

DRIVE GEARING

Model	LeTourneau 51-B
-------	-----------------

In-line gear train mounted within the rim of the tire, transmitting power from the traction motor to the tire/rim assembly.

Each drive unit consists of a planetary gear train, hub structure, spindle structure, primary gearbox, and a bearing carrier assembly with independent circulating filtration system.

Total Reduction	140:1
-----------------	-------

DRIVE SYSTEM COOLING AIR

Function	Filtered Inlet Air Cools Control Box, A.C. Generator And Traction Motors
Blower	Backward Inclined Blade Fan
Drive	Hydraulic Motor
Filter Make	LeTourneau, Self Cleaning, KLENZ™ System



TIRES

STANDARD

Front And Rear Tires	52/80-57 68 PR (L-4)
Rims	36-57

OPTIONAL

Front And Rear Tires	50/80-57 (L-4)	55/80R-57 (L-5)
Rims	36-57	44-57



TRAVELING SPEED

INFINITELY VARIABLE

Forward And Reverse	0-10 mph (0-16.1 Kph)
---------------------	-----------------------



OPERATING CAPACITIES, WEIGHTS AND DIMENSIONS

DIMENSIONS

STANDARD LIFT

HIGH LIFT

Bucket Capacity	28 yd ³	(21.41 m ³)	26 yd ³	
Operating Payload	84,000 lbs	(38,102 kgs)	78,000 lbs.	(35,381 kgs)
Bucket Width	20 ft. 7 in.	(6.27 m)	20 ft. 7 in.	(6.27 m)
Bucket Width with Deflectors	22 ft. 7 in.	(6.88 m)	22 ft. 7 in.	(6.88 m)
Hinge-Pin Height	28 ft. 1 in.	(8.55 m)	29 ft. 10 in.	(9.09 m)
Dump Clearance 45° Discharge	21 ft. 0 in.	(6.40 m)	23 ft. 6 in.	(7.16 m)
Reach @ Full Lift 45° Discharge	8 ft. 11 in.	(2.71 m)	9 ft. 6 in.	(2.90 m)
Digging Depth	0 ft. 9 in.	(0.23 m)	0 ft. 15 in.	(0.38 m)
Height - Bucket Fully Raised	36 ft. 3 in.	(11.05 m)	38 ft. 0 in.	(11.58 m)
Ground Clearance	2 ft. 1 in.	(0.64 m)	2 ft. 1 in.	(0.64 m)
Overall Length Bucket Down	55 ft. 0 in.	(16.76 m)	57 ft. 0 in.	(17.37 m)
Overall Length Carry Position	54 ft. 0 in.	(16.46 m)	56 ft. 0 in.	(17.07 m)
Wheel Base	21 ft. 3 in.	(6.48 m)	21 ft. 3 in.	(6.48 m)
Tread	14 ft. 7 in.	(4.45 m)	14 ft. 7 in.	(4.45 m)
Width Outside Tires	18 ft. 11 in.	(5.77 m)	18 ft. 11 in.	(5.77 m)
Height Over Cab	19 ft. 10 in.	(6.05 m)	19 ft. 10 in.	(6.05 m)
Static Tipping Loads				
Straight	229,434 lbs	(104,071 kgs)	210,070 lbs	(95,485 kgs)
Full 45° Turn	192,950 lbs	(87,522 kgs)	181,460 lbs	(82,480 kgs)
Breakout Force	220,000 lbs	(99,792 kgs)	217,930 lbs	(99,060 kgs)
Operating Weight	400,000 lbs	(181,438 kgs)	405,000 lbs	(184,090 kgs)



STANDARD CONFIGURATION

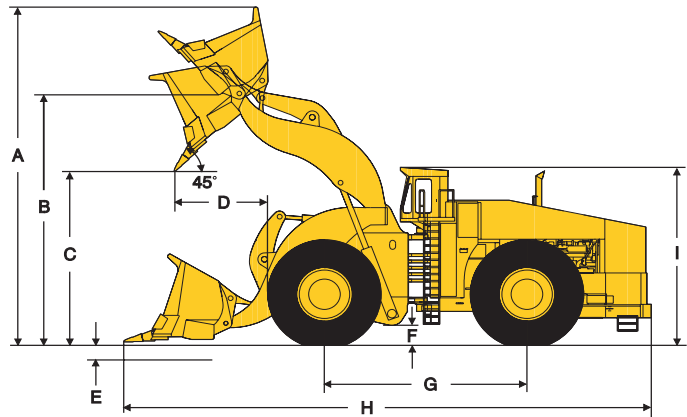
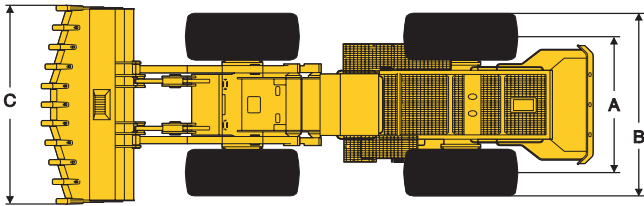

Top View

(A)	14 ft. 7 in.	(4.45 m)
(B)	18 ft. 11 in.	(5.77 m)
(C)	20 ft. 7 in.	(6.27 m)

Side View

STANDARD LIFT

HIGH LIFT

(A)	36 ft. 3 in.	(10.97 m)	38 ft. 0 in.	(11.58 m)
(B)	28 ft. 1 in.	(8.53 m)	29 ft. 10 in.	(9.09 m)
(C)	21 ft. 0 in.	(6.50 m)	23 ft. 6 in.	(7.16 m)
(D)	8 ft. 11 in.	(2.69 m)	9 ft. 6 in.	(2.90 m)
(E)	0 ft. 9 in.	(0.23 m)	1 ft. 3 in.	(0.38 m)
(F)	2 ft. 1 in.	(0.64 m)	2 ft. 1 in.	(0.64 m)
(G)	21 ft. 3 in.	(6.48 m)	21 ft. 3 in.	(6.48 m)
(H)	55 ft. 0 in.	(16.76 m)	57 ft. 0 in.	(17.37 m)
(I)	19 ft. 10 in.	(6.05 m)	19 ft. 10 in.	(6.05 m)



ELECTRICAL AND MECHANICAL BRAKING

PRIMARY BRAKING SYSTEM

Electric Braking (Retarding) is designed as the primary braking system which can be controlled from the accelerator or retard/brake pedal. This solid-state, non-wearing parts braking system will bring the loader to a full stop without application of the air-operated disc brakes.

EMERGENCY AND PARKING BRAKE SYSTEM

Armature speed disc brakes, spring-actuated air release, automatic actuation on all four wheels in the event of pressure loss.



FRAME

The unique LeTourneau box structure frames are fabricated from high-strength, low-alloy steel with excellent weldability and low temperature properties throughout. The front axle is an integral, fixed part of the frame. The rear axle is allowed to oscillate a total of +/-11 degrees on the rear frame.

The independent power module mounting system is cradled within the rear frame by a three-point isolation system.



INDEPENDENT STEERING AND HOIST SYSTEMS

ARTICULATED POWER STEERING

Joystick controlled articulation - full-time hydrostatic power steering. Constant engine RPM provides full steering response regardless of vehicle speed.

Operating Pressure	3400 PSI	(23,426 kPa)
Articulation Angle	42° Each Side	
Turning Radius - STD Lift	40 ft. 6 in.	(12.34 m)
High Lift	42 ft. 1 in.	(12.82 m)

HOIST AND BUCKET CONTROL

Both hoist and bucket control functions are incorporated into a single joystick control. Hydraulic metered pilot-controlled hoist system is independent of the steering system utilizing single stage, double-acting cylinders mounted outside of the front frame.

Standard and High Lift Cycle Times:

Hoist	13 Seconds
Dump	3 Seconds
Float	5 Seconds
Total Time	21 Seconds



HYDRAULIC SYSTEM

PUMP DRIVE BOX

LeTourneau, Inc. Gearbox
Wet Spline Design with Pressurized And Filtered Lubrication

Ratio 1:1

PUMPS

Main	Piston (3)	375 GPM	(1419 l/min)
Steering	Piston	90 GPM	(341 l/min)
Fan Drive	Piston	45 GPM	(170 l/min)
Blower	Piston	60 GPM	(227 l/min)
Cooling System			
Circulating Pump	Vane	100 GPM	(379 l/min)

VALVES

Main	Three (3)	185 GPM	(700 l/min)
	Relief Pressure	3300 PSI	(22737 kPa)
Steering	One (1)	90 GPM	(341 l/min)
	Relief Pressure	3400 PSI	(23426 kPa)

CYLINDERS

Double-Acting, Single-Stage

Hoist	Diameter And Stroke (Standard And High Lift) 13.5 in. X 74.5 in. (343 mm X 1892 mm)
Bucket	Diameter And Stroke (Standard And High Lift) 10.0 in. X 41.5 in. (254 mm X 1054 mm)
Steering	Diameter And Stroke 7.5 in. X 30.0 in. (191 mm X 762 mm)

FILTERS

Full System	Return-Flow	10 Micron Absolute
Drivers		10 Micron Absolute
Gearbox		10 Micron Absolute
Pump (Case Drain)		10 Micron Absolute



GENERAL SERVICE DATA

FLUID CAPACITIES

Fuel Tank	925 gals	(3501 l)
Hydraulic Tank	375 gals	(1,419 l)
Cooling System	101 gals	(382 l)
Crankcase (Includes Filters)		
Detroit Diesel	58 gals	(220 l)
Gearbox	7 gals	(27 l)
Drivers (Each)	36 gals	(136 l)



OPERATOR ENVIRONMENT

CAB

Spacious, ergonomically designed operator's cab features a low interior sound level and is mounted directly over the center articulation point, providing excellent visibility. Joystick controlled steering comes standard along with the unique LeTourneau single joystick boom and bucket controls. Climate control vents are strategically located throughout the cab. The joystick operator's seat has adjustable air suspension along with retractable seat belts.



STANDARD FEATURES

Engine Coolant Temperature Gauge
 Engine Lube-Oil Pressure Gauge
 Fuel Level Gauge
 Hour Meter
 Speedometer
 System Air Pressure Gauge

STANDARD INDICATOR LIGHTS AND AUDIBLE ALARMS

The operator is informed of a potential problem by an audible alarm and text messages on a computer display. The digital display also provides repair technicians with operational data and fault messages in the event of a mechanical, electrical or electronic malfunction.

Three warning lights immediately advise the operator of the severity/condition of various engine, hydraulic, electrical and electronic systems of the loader (RED, AMBER and BLUE).

STANDARD EQUIPMENT

Access Ladder Light
 Air Clean-Out Hose in Cab
 Air Conditioning, Filtered And Pressurized
 Air Dryer System
 Air Horn
 Air Tank Bleed System
 Automatic Adjustable Lift Height Cut Off
 Automatic Bucket Leveling Device
 Automatic Cabinet Lights
 Automatic Lubrication System
 Backup Alarm, Audible
 Battery Disconnect Switch
 Cigar/Cigarette Lighter
 Convex Mirrors
 Dual Door Interlock System
 Dust Detectors, Engine Intake Air
 Emergency Stop Kit - Cab and Remote Mounted
 Engine Compartment Light
 Five (5) Gallon Windshield Washer Reservoir
 FOPS, Falling Object Protection System
 Ground Fault Electrics
 Heater-Defroster, High-Output
 HID Headlights
 High, Low Idle Switch
 Idle Timer
 Illuminated Instrument Panel
 Interior Lights
 Joystick Hoist and Bucket Controls
 Joystick Steering
 Ladder Walkway-Rear Access
 LINCSTM - LeTourneau Integrated Network Control System
 Manual Fire Extinguisher, 21 lbs (9.53 kgs)
 Maintenance Lock-Out Switch
 Mirror, Rearview
 Overspeed Alarm
 Parking Brake
 Rear Tow Hitch
 Rock Deflectors
 ROPS, Rollover Protective Structure
 Seat Belt
 Standby Power Capability
 Sun Visor
 Tinted Safety Glass Throughout
 Turn Signals
 Twelve (12) Volt Power Supply
 Windshield Wiper And Washer, Front And Rear
 Work Lights, 110 Volt - 500 Watt (4) Front (2) Rear



OPTIONAL FEATURES

Auxiliary Oil Cooler
Auxiliary Steering System
Central Service With Fast Fuel
Engine Heating System Oil And Water
Fast Fuel
Fluid Sampling Kit
Grease Reservoir Heater
Hydraulic Tank And Battery Heater
Jump Start Kit
Manual Fire Detection And Suppression System
Remote Monitoring System
Standby Power



BUCKET HARDWARE OPTIONS

Lip Wear Protection and Teeth
Skid Plates - Replaceable
Wear Liner Kits

For additional bucket sizes and hardware options consult your LeTourneau, Inc. dealer representative.



SAFETY CERTIFICATION

Meets the following MSHA, SAE and ISO Safety Standards:

Brake Performance Test SAE J1473 / ISO 3450
Capacity Rating - Loader Bucket SAE J742
Exterior Sound Level SAE J88
FOPS SAE J231 / ISO 3449
Interior Sound Level SAE J919
Rated Operating Load for Loaders SAE J818
ROPS SAE J1040 / ISO 3471/1
Steering Test SAE J1511 / ISO 5010

Please Note: Standard/Optional Equipment, Features and Performance conform to U.S. and International Codes as Required.

LeTourneau, Inc. has made every effort to make these specifications as accurate as possible at the time of printing. However, we reserve the right to make changes and improvements at any time without notice, in equipment, materials and specifications. To ensure the most current information, please contact your LeTourneau, Inc. dealer representative.

