

# LOADER SPECIFICATIONS

# L-950



Note: Optional equipment shown in photo.



## LeTourneau, Inc.



## POWER MODULE

### DIESEL POWER OPTIONS

#### DETROIT DIESEL ENGINE

Model	16V 2000
Type	4-Cycle Turbocharged
Rated Power	1050 HP (783 kW @ 1900 RPM)
Cylinders	Sixteen (16)
Bore And Stroke	5.12 in. X 5.91 in. (130 mm X 150 mm)
Displacement	1944 cu. in. (31.86 liters)

#### CUMMINS DIESEL ENGINE

Standard Model	QST 30
Type	4-Cycle Turbocharged/Aftercooled
Rated Power	1050 HP (783 kW @ 1900 RPM)
Cylinders	Twelve (12)
Bore And Stroke	5.51 in. X 6.5 in. (140 mm X 190 mm)
Displacement	1861 cu. in. (30.5 liters)

#### RADIATOR/OIL COOLER MODULE

Type	Split Flow Side by Side Thermostatically Controlled Independent Hydraulic Motor-Driven Radiator Fan
Fan Speeds	2-Speed
Cooling Capacity	50 gals (190 liters)

#### AIR FILTRATION

LeTourneau, Self Cleaning, KLENZ™ System  
99.9% Efficiency Filtered Down to 0.3 Microns  
Supply Filtered Air For:

Engine Air
Drive System Cooling
Pressurized Cab

#### EXHAUST SYSTEM

Low Restriction Mufflers With Vertical, Mid-Hood Discharge



## CONTROL SYSTEM-LINCS™

### LeTourneau Integrated Network Control System - LINCS™

Switched Reluctance (SR) Propulsion System  
Microprocessor Based Full Digital Control and Monitoring  
• Hydraulics • Electrics • Engine • Traction Drive

Modular Design

Built-in Diagnostics • Dash Display and Keypad

Solid State AC-DC Phase Controlled Traction Drive

SR Drive Advantages Include: No Contactors, No Power Switch Gear, and No Armatures or Brushes on Traction Motors

#### LINCS™ LOAD WEIGH

The LINCS™ load weigh unit is an integrated microprocessor based data logging and storage system. The system displays real time load per pass, per truck and total loads; as well as alerting the operator to overload conditions.

It is capable of storing several months worth of loader production information.

LINCS™ can interface with most radio dispatch systems for Real-Time monitoring.

**LeTourneau, Inc.**



## PROPULSION SYSTEM

#### A.C. GENERATOR

Model	LeTourneau 6-R A.C. Generator
Type	Alternating-Current, 3-Phase, 4-Pole
Excitation	Solid State

#### TRACTION MOTORS

Model	LeTourneau B40
Type	Switched-Reluctance
Number	Four (4) - All Wheel Drive

#### DRIVE GEARING

Model	LeTourneau 35A
-------	----------------

In-line gear train mounted within the rim of the tire, transmitting power from the traction motor to the tire/rim assembly.

Each drive unit consists of a three-stage planetary gear train, rotating hub structure, fixed spindle structure, and taper roller.

Total Reduction	95.6:1
-----------------	--------

Main bearings mounted on the spindle to support the rotating hub assembly.

#### DRIVE SYSTEM COOLING AIR

Function	KLENZ™-Filtered Air Cools Electrical Control Boxes, A.C. Generator And Traction Motors
Blower Drive	Backward Inclined Blade Fan 2-Speed Hydraulically Driven

#### 24-VOLT ELECTRICAL

Batteries	Four (4) 12-Volt
Model	4D
Starter	24 VOLT
Alternator	120 Amp With Integral Voltage Regulator



## TIRES

#### STANDARD

Front And Rear Tires	45/65-45 Bias Ply 46 PR L-5 Tread
Rims	36-45

#### OPTIONAL

Front And Rear Tires	45/65-R45 Radial Tire
----------------------	-----------------------



## TRAVELING SPEED

#### INFINITELY VARIABLE

Forward And Reverse	0-15 mph (0-24.1 Kph)
---------------------	-----------------------

**L-950 Specifications**



## OPERATING CAPACITIES, WEIGHTS AND DIMENSIONS

	STANDARD		HIGH LIFT	
Bucket Capacity	18 yd <sup>3</sup>	(13.76 m <sup>3</sup> )	16 yd <sup>3</sup>	(12.2 m <sup>3</sup> )
Operating Payload	54,000 lbs	(24,494 kgs)	48,000 lbs	(21,772 kgs)
Bucket Width	16 ft 5 in.	(5.00 m)	16 ft 5 in.	(5.00 m)
Bucket Width With Deflectors	18 ft 3 in.	(5.56 m)	18 ft 3 in.	(5.56 m)
Hinge-Pin Height	22 ft 8 in.	(6.91 m)	24 ft 5 in.	(7.44 m)
Dump Clearance 52° Discharge	15 ft 6 in.	(4.72 m)	17 ft 3 in.	(5.26 m)
Reach @ Full Lift 52° Discharge	8 ft 7 in.	(2.61 m)	9 ft 0 in.	(2.74 m)
Digging Depth	0 ft 6 in.	(0.15 m)	0 ft 6 in.	(0.15 m)
Height - Bucket Fully Raised	30 ft 3 in.	(9.22 m)	32 ft 0 in.	(9.75 m)
Ground Clearance	1 ft 10 in.	(0.56 m)	1 ft 10 in.	(0.56 m)
Overall Length Bucket Down	49 ft 10 in.	(15.19 m)	51 ft 7 in.	(15.72 m)
Overall Length Carry Position	48 ft 9 in.	(14.86 m)	50 ft 6 in.	(15.39 m)
Wheelbase	19 ft 6 in.	(5.94 m)	19 ft 6 in.	(5.94 m)
Tread	12 ft 3 in.	(3.73 m)	12 ft 3 in.	(3.73 m)
Width Outside Tires	16 ft 0 in.	(4.88 m)	16 ft 0 in.	(4.88 m)
Height Over Cab	19 ft 9 in.	(6.0 m)	19 ft 9 in.	(6.0 m)
Static Tipping Loads:				
Straight	153,000 lbs	(69,400 kgs)	148,000 lbs	(67,133 kgs)
Full 42° Turn	135,000 lbs	(61,236 kgs)	131,000 lbs	(59,421 kgs)
Breakout Force	160,000 lbs	(712 kilonewtons)	165,000 lbs	(734 kilonewtons)
Operating Weight	235,000 lbs	(106,594 kgs)	240,000 lbs	(108,862 kgs)



## STANDARD CONFIGURATION

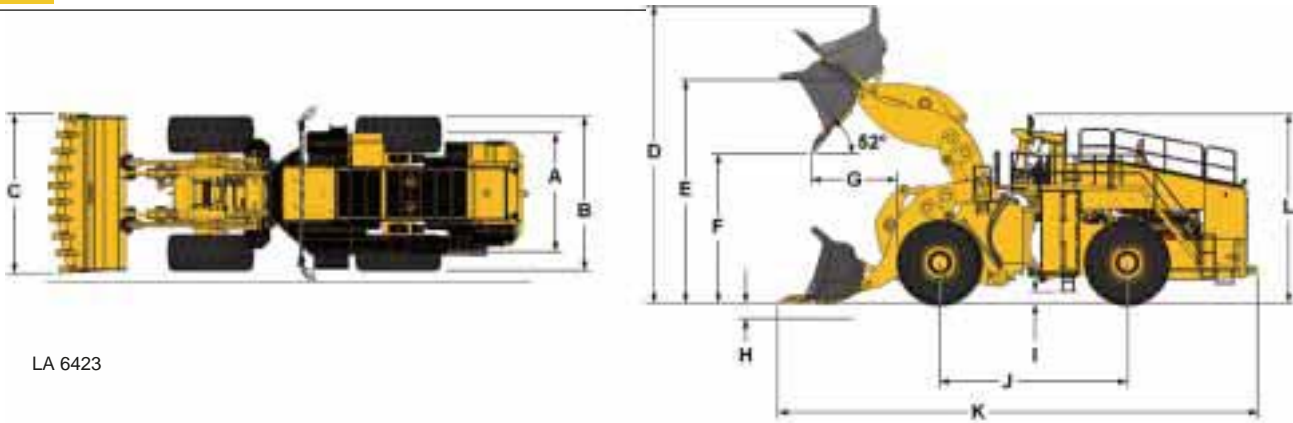

LA 6423

### Top View

<b>(A)</b>	12 ft 3 in.	(3.73 m)
<b>(B)</b>	16 ft 0 in.	(4.87 m)
<b>(C)</b>	16 ft 5 in.	(5.00 m)

### Side View

	STANDARD	HIGH LIFT
<b>(D)</b>	Bucket 18 yd <sup>3</sup> (13.00 m <sup>3</sup> )	Bucket 16 yd <sup>3</sup> (12.3 m <sup>3</sup> )
<b>(E)</b>	30 ft 3 in. (9.22 m)	32 ft 0 in. (9.75 m)
<b>(F)</b>	22 ft 7.5 in. (6.89 m)	24 ft 5 in. (7.44 m)
<b>(G)</b>	15 ft 6 in. (4.72 m)	17 ft 3 in. (5.25 m)
<b>(H)</b>	8 ft 7 in. (2.61 m)	9 ft 0 in. (2.73 m)
<b>(I)</b>	0 ft 8 in. (0.19 m)	0 ft 6 in. (0.15 m)
<b>(J)</b>	1 ft 10 in. (0.55 m)	1 ft 10 in. (0.55 m)
<b>(K)</b>	19 ft 6 in. (5.94 m)	19 ft 6 in. (5.94 m)
<b>(L)</b>	49 ft 10 in. (15.18 m)	50 ft 4 in. (15.33 m)
	19 ft 9 in. (6.02 m)	19 ft 9 in. (6.02 m)

All dimensions calculated with teeth on bucket.



## ELECTRICAL AND MECHANICAL BRAKING

### PRIMARY BRAKING SYSTEM

Electric Braking (Retarding) is designed as the primary braking system which can be controlled from the accelerator or retard/brake pedal. This solid-state, non wearing parts braking system will bring the loader to a full stop without application of the air-operated disc brakes used for backup.

### EMERGENCY AND PARKING BRAKE SYSTEM

Motor speed disc brakes, spring-actuated air release, automatic actuation on all four wheels in the event of pressure loss.



## FRAME

The unique LeTourneau external box structure frames are fabricated from high-strength, low-alloy steel with excellent weldability and low temperature properties through-out. The front axle is an integral, fixed part of the frame. The rear axle is allowed to oscillate a total of +/- 11 degrees to the rear frame.

The independent power module mounting system is cradled within the rear frame by a three-point isolation system.



## INDEPENDENT STEERING AND HOIST SYSTEM

### ARTICULATED POWER STEERING

Articulating frame - full-time joystick controlled power steering. The LeTourneau electric drive, with its constant-rated engine RPM, provides full steering response regardless of vehicle speed.

Operating Pressure	2500 PSI	(17,238 kPa)
Articulation Angle	42° Each Side	
Turning Radius		
Standard Lift	32 ft 3 in.	(9.84 m)
High Lift	35 ft 3 in.	(10.75m)

### HOIST AND BUCKET CONTROL

Both hoist and bucket control functions are incorporated into a simple joystick control. Hydraulic metered, pilot-controlled hoist system is independent of the steering system utilizing single stage, double-acting cylinders mounted outside of the front frame.

Standard/High Lift Cycle Times:

Hoist	10 Seconds
Dump	2 Seconds
Float	5 Seconds
Total Time	17 Seconds



## HYDRAULIC SYSTEM

### PUMP DRIVE BOX

LeTourneau, Inc. Gearbox  
Wet Spline Design With Pressurized And Filtered Lubrication

Ratio 1:1

### PUMPS

Main Pumps	(2) Piston Pump	250 GPM	(946 l/min)
Steering	Vane Pump	90 GPM	(340 l/min)
Fan/Blower Drive	Tandom Piston Pump	45/45 GPM	(170/170 l/min)
Cooling System Circulating	Vane	110 GPM	(416 l/min)
Gearbox Lube		17 GPM	(64 l/min)

### VALVES

Main	Relief Pressure	3700 PSI (25,511 kPa)
Steering	Relief Pressure	2500 PSI (17,238 kPa)

### CYLINDERS

Double-Acting, Single-Stage

Hoist	Diameter And Stroke (Standard and High Lift) 10 in. X 64.5 in. (254 mm X 1638 mm)
Bucket	Diameter And Stroke (Standard and High Lift) 10 in. X 25.5 in. (254 mm X 648 mm)
Steering	Diameter And Stroke 7.5 in. X 30 in. (190 mm X 762 mm)

### FILTERS

Full System,	Return-Flow	10 Micron Absolute
Gearbox		10 Micron Absolute
Piston Pump (Case Drain)		10 Micron Absolute



## GENERAL SERVICE DATA

### FLUID CAPACITIES

Fuel Tank	565 gals	(2,138 l)
Hydraulic Tank	260 gals	(984 l)
Cooling System	50 gals	(190 l)
Crankcase (Includes Filters)		
Cummins	35 gals	(132 l)
Detroit Diesel	25 gals	(94 l)
Gearbox	5 gals	(19 l)
Drivers (Each)	6.1 gals	(23 l)



## OPERATOR ENVIRONMENT

### CAB

Spacious, ergonomically designed operator's cab is mounted directly over the center articulation point, assuring driver comfort and excellent visibility. The cab is independently elastomer-mounted separate from the ROPS structure, minimizing vibration and sound transmission. Only KLENZ™ filtered air enters the pressurized cab, which includes a combination high capacity air conditioning/heater-defroster. The operator's seat is 9-way adjustable with air suspension and retractable seat belt. Standard features also include joystick steering, joystick hoist and bucket control, tinted thermopane glass, sun visor and full insulation for thermal and accoustical dampening.



## STANDARD FEATURES

Engine Coolant Temperature Gauge  
 Engine Lube-Oil Pressure Gauge  
 Fuel Level Gauge  
 Hour Meter  
 Speedometer  
 System Air Pressure Gauge

### STANDARD INDICATOR LIGHTS AND AUDIBLE ALARMS

The operator is informed of a potential problem by audible alarm and indicator lights in addition to text messages on an in-dash display. The digital display provides repair technicians with operational data and fault messages in the event of mechanical, electrical or electronic malfunction.

Three warning lights immediately advise the operator of the severity/condition of various engine, hydraulic, electrical and electronic systems of the loader. (RED, AMBER and BLUE).

### STANDARD EQUIPMENT

Access Ladder Light  
 Air Clean-Out Hose In cab  
 Air Conditioning / Heater-defroster Filtered And Pressurized  
 Air Dryer System  
 Air Horn  
 Air Tank Bleed System  
 Automatic Adjustable Lift Height Cut Off  
 Automatic Bucket Leveling Control  
 Automatic Electrical Cabinet Lights  
 Automatic Lubrication System  
 Back-up Alarm, Audible  
 Battery Disconnect Switch  
 Brake Lights  
 Cigar / Cigarette Lighter  
 Electrical Cabinet Interlock  
 Emergency Stop Buttons - Cab and Remote Mounted  
 Engine Compartment Light  
 Fire Extinguisher, Manual, 21 lbs (9.53 kgs)  
 FOPS - Falling Object Protection System  
 Ground Fault Electrics  
 High, Low Idle Control Switch  
 Idle Timer  
 Illuminated Instrument Panel  
 Interior Lights  
 Joystick Hoist and Bucket Controls  
 Joystick Steering  
 LINCST™ - LeTourneau Integrated Network Control System  
     with Load Weigh & Full Vehicle Monitoring  
 Maintenance Lock-Out Switch  
 Mirrors, Rearview (Parabolic)(2)  
 Operator Seat - 9-Way Adjustable w/ Retractable Seat Belt  
 Overspeed Alarm  
 Parking Brake  
 Rear Vehicle Access  
 ROPS - Rollover Protection Structure  
 Sun Visor  
 Tinted Safety Glass Throughout (Thermopane)  
 Tow Hitch, Rear  
 Turn Signals  
 Twelve (12) Volt Power Supply  
 Windshield Washer Reservoir (5 gallons)  
 Windshield Wiper and Washer, Front & Rear  
 Work Lights, 110 Volt - 500 Watt (4) Front (2) Rear



## OPTIONAL FEATURES

Auxiliary Steering System  
 Central Service with Fast Fuel  
 Engine Heating System, Oil and Water  
 Fast Fuel  
 Fire Detection System  
 Fluid Sampling Kit  
 Grease Reservoir Heater  
 Hydraulic Tank and Battery Heater  
 Jump Start Kit  
 L&M Mesabi Radiator  
 Manual Fire Suppression System  
 Remote Monitoring System



## SAFETY CERTIFICATION

### Meets the following MSHA, SAE and ISO Safety Standards:

Brake Performance Test SAE J1473 / ISO 3450  
 Capacity Rating - Loader Bucket SAE J742  
 Exterior Sound Level SAE J88  
 FOPS SAE J231 / ISO 3449  
 Interior Sound Level SAE J919  
 Rated Operating Load for Loaders SAE J818  
 ROPS SAE J1040 / ISO 3471  
 Steering Test SAE J1511 / ISO 5010



## OPTIONAL QUICK CHANGE BUCKET SYSTEM

### STANDARD, SAE-RATED CAPACITY: 48,000 LBS (21,769 KGS)

	Rock	Coal
Standard Lift	16 yd <sup>3</sup> (12.3 m <sup>3</sup> )	24 yd <sup>3</sup> (18.5 m <sup>3</sup> )

### HIGH, SAE-RATED CAPACITY: 45,000 LBS (20,409 KGS)

	Rock	Coal
High Lift	15 yd <sup>3</sup> (10 m <sup>3</sup> )	22 yd <sup>3</sup> (17 m <sup>3</sup> )

The quick-change bucket has three hooks and two ears on the back of the bucket and a quick-change coupling system with hydraulic cylinders and a control valve on the coupler assembly. An experienced operator can change the bucket in less than five minutes.

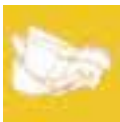

## BUCKET HARDWARE OPTIONS

Skid Plates - Replaceable  
 Lip Wear Protection  
 Wear Liner Kits

For actual bucket configuration and sizing, consult your LeTourneau, Inc. dealer representative.

Please Note: Standard/Optional Equipment, Features and Performance conform to U.S. and International Codes as Required.

LeTourneau, Inc. has made every effort to make these specifications as accurate as possible at the time of printing. However, we reserve the right to make changes and improvements at any time without notice, in equipment, materials and specifications. To ensure the most current information, please contact your LeTourneau, Inc. dealer representative.



## LeTourneau, Inc.

P.O. Box 2307 • Longview, TX 75606 • (903) 236-6598 • FAX (903) 236-6585  
 www.letourneau-inc.com • email:equipment.sales@letourneau-inc.com